



MACH™ SERIES LIFTS

MOBILE COLUMN LIFTING SYSTEMS

14,000 LBS. TO 18,800 LBS. COLUMN CAPACITIES



The faster and easier choice for your maintenance facility.



POWERED BY **RedFire**  PROUDLY MADE IN MADISON, INDIANA



ENVIRONMENTALLY-FRIENDLY



Unmatched lifting versatility with the mobility to monitor and adjust anywhere in the shop.



MCHM419

Shown: MCHM419U1A00 / Wireless remote-controlled model

FLEXMAX™ REMOTE LIFTING SYSTEMS

FLEXMAX™ WIRELESS REMOTE-CONTROLLED LIFTING

Premium FLEXMAX™ lifts provide unmatched lifting versatility and flexibility.

EXCLUSIVE!

Wireless, hand-held remote control walks the technician through the system set up.

REDFIRE™ Technology gives you the fastest set up time and easiest lift operation in the industry.



FLEXMAX™ single column controls allow user with remote to select and change column groups and cycle lifts from any column.



Exclusive **LOCK LIGHT™** indicates when a column is on its locks. Standard with FLEXMAX™ lifts.

FLEXMAX™ LIFT FEATURES:

- Wireless, Remote-Controlled Lifting
- Powered by RedFire™ Technology
- Operational Controls at Each Column
- Configure Sets of 2, 4, 6 or 8 Columns
- 24V DC Batteries Operate System
- 110V On-board Charger
- Easy to Move Adjustable Forks
- Wheel Rim Size: 9" to 24"
- Forklift Pockets for Lift Relocation
- Spring Loaded Steering and Braking
- Rubber-coated Steel Wheels
- Environmentally-friendly Benefits
- Inverted Hydraulic Cylinder Rod



WIRELESS CONTROLS
NO CABLES / NO CORDS



POWERED BY

RedFire



Shown: MCHM419U100

FLEXMAX419

18,800 lbs. capacity column



WATCH THE PRODUCT VIDEO

See how fast and easy it is to set up and operate FLEXMAX lifts

MCHM19 FLEXMAX™ 18,800 LBS. COLUMN CAPACITIES

Group of 2 columns / 37,600 lbs. Capacity
Group of 4 columns / 75,200 lbs. Capacity
Group of 6 columns / 112,800 lbs. Capacity
Group of 8 columns / 150,400 lbs. Capacity

Rise: 69" (1760 mm)

Column width: 45 1/2" (1156mm)

Clearance / fork to column: 10" (254mm)

Speed of rise: 78 seconds

Charging voltage: 110v charger* (2.5 amps max.)

LIFT COLOR IS BLACK



MCHM14 FLEXMAX™ 14,000 LBS. COLUMN CAPACITIES

Group of 2 columns / 28,000 lbs. Capacity
Group of 4 columns / 56,000 lbs. Capacity
Group of 6 columns / 84,000 lbs. Capacity
Group of 8 columns / 112,000 lbs. Capacity

Rise: 69" (1760 mm)

Column width: 43" (1092 mm)

Clearance / fork to column: 10" (254 mm)

Speed of rise: 68 seconds

Charging voltage: 110v charger* (2.5 amps max.)

LIFT COLOR IS BLACK * Call factory for alternate voltage



MACH™ SERIES LIFTS

WIRELESS MCHW18 SERIES LIFTS

Take advantage of the power and mobility to make repairs anywhere in your shop!

The set-up time and lifting speed beats the competition hands down with fewer steps to put the lift in service.

MACH™ LIFT FEATURES:

- Intuitive Operational Controls with No Master/Slave Column
- Configure Sets of 2, 4, 6 or 8 Columns
- 24V DC Batteries Operate System
- 110V On-board Charger
- Easy to Move Adjustable Forks
- Wheel Rim Size: 9" to 24"
- Forklift Pockets for Lift Relocation
- Spring Loaded Steering and Braking
- Rubber-coated Steel Wheels
- Environmentally-friendly Benefits
- Inverted Hydraulic Cylinder Rod



WATCH THE PRODUCT VIDEO

Learn more about our industry-leading lift features



WIRELESS CONTROLS
NO CABLES / NO CORDS



Shown: MCH418100

MCHW418

18,000 lbs. capacity column

MCHW18

18,000 LBS. COLUMN CAPACITIES

Group of 2 columns / 36,000 lbs. Capacity
Group of 4 columns / 72,000 lbs. Capacity
Group of 6 columns / 108,000 lbs. Capacity
Group of 8 columns / 144,000 lbs. Capacity

Rise: 69" (1760 mm)

Column width: 45 1/2" (1156mm)

Clearance / fork to column: 10" (254 mm)

Speed of rise: 78 seconds

Charging voltage: 110v charger* (2.5 amps max.)

LIFT COLOR IS RED



WIRED MCH14 SERIES LIFTS

SAME LEADING FEATURES WITH CORDED COLUMN COMMUNICATION

INTUITIVE CONTROLS AT EACH COLUMN
SAVE TIME WITH EACH SERVICE CYCLE WITH THESE FEATURES

MCH14 WIRED

14,000 LBS. COLUMN CAPACITIES

Group of 2 columns / 28,000 lbs. Capacity
Group of 4 columns / 56,000 lbs. Capacity
Group of 6 columns / 84,000 lbs. Capacity
Group of 8 columns / 112,000 lbs. Capacity

Rise: 69" (1760 mm)

Column width: 43" (1092 mm)

Clearance / fork to column: 10" (254 mm)

Speed of rise: 68 seconds

Charging voltage: 110v charger* (2.5 amps max.)

LIFT COLOR IS BLACK ★ Call factory for alternate voltage

Communication Cable

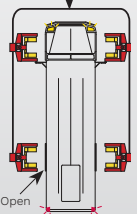

Innovative Horseshoe Wiring

- Three cables versus 4 form a horseshoe
- Front or back of the lift is always open
- No need to disconnect and reconnect cables



OPTIONAL Retractable Cord Reels with Quick Connect Cables

- Easy one-handed connectivity
- No waste of time handling cables

VERSATILE DRIVE-ON CONVERSION KIT

M140015 MACH4 PLUS RUNWAY SYSTEM

For Use with MCHM19
or MCHW18 Series
Column Lifts

60,000 lbs. Capacity
Runway Length: 33'

Convert your mobile
column series lifts into
a heavy duty drive-on
lift for vehicle inspection,
scheduled maintenance,
and wheel service.

- Accommodate wheelbases up to 33' (396")
- Fully hydraulic operation
- Fast battery operation with controls at all 4 columns
- No 4 post cables or sheaves to maintain
- Internal airlines included for optional rolling jacks and air tools



Shown: MCH418U100 with M140015 runway system

SPECIFICATIONS	M140015RD
Lifting Capacity	60,000 lbs. (27215kg) †
Runway Length	33' (396" / 10058mm)
Max. Rise / Floor to top of runway	78" (1981mm)
Length Overall	40' 7-1/2" (12382mm)
Width Overall - outside controls	15' 11" (4851mm)
Height of Columns when raised	144 - 3/4" (3677mm)
Width of Runways	28" (711mm)
Drive Thru Between Columns	11'-10" (3607mm)
Runway Spacing	45" (1143mm)
Rise Time	78 seconds
Ramp Angle	10 degrees
Power Usage	Battery powered Charges on 110V

† WITH MCH18 SERIES and FLEX MAX 19 SERIES LIFTS



Shown: MCH418U100 with M140015 runway system

OPTIONAL RUNWAY LIFT ACCESSORIES

Rolling Bridge Jacks

Air operated rolling bridge jacks can be attached to the runways creating additional lifting options for greater versatility.

FOR 60,000 lbs. CAPACITY LIFTS

RJ25BK / 25,000 lbs. (11363 kg) with lock
RJ30BK / 30,000 lbs. (13610 kg) with lock



Portable Maintenance Jack Stands

RS20SYL / Screw-Type Adjustable
56.1"-82.3" / 20,000 lbs. Capacity

RS2052SYL / Screw-Type Adjustable
34.3 "-55.5" / 20,000 lbs. Capacity

RS20-VAYL / V-Shaped Adapter
For 20K Jack Stands - 1 per stand



All jack stands meet the required ASME PASE-2014 safety requirements for portable service equipment.

Always use safety stands when installing or removing heavy components.

Air Operated Tire and Wheel Lifts

Offers maximum maneuverability and adjustable lifting and lowering speeds. Provides technicians with responsive and easy positioning of the tire and wheel, easy alignment of the wheel and hub and a quick transfer to the wheel balancer. Includes air hose and auxiliary air tool connection.

MW-200 / 200 lbs. capacity

MW-500 / 500 lbs. capacity



LED Runway Lighting Kit

FA5700 / TECH LIGHT™ Line Light 4



Attach the four 54" light wands to runways for effective, efficient lighting where you need it.

Lighting unit includes

- 60W power supply unit
- 16' cable lengths
- 8 magnetic suspensions
- 120V AC input voltage at 60hz

Drive-Thru Ramp Kit M140099RD / 10' Ramps

Adding a drive-thru ramp kit creates a quick and easy on-off service operation for service bays.

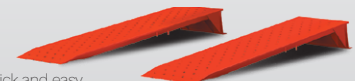

FORE and AFT END LIFT KIT

M140168YL

WHEELS-FREE FRAME-ENGAGING END LIFT KIT

For Use With Two MCHM19,
MCHW18, MCHM14, or
MCH14 Mobile Columns on
Full Frame Vehicles.

18,000 lbs. Maximum Capacity / 9K per column
Widest reach in the industry at 43"



Standard with 3.5", 5", and 10"
adapter extensions for greater reach.



M110108BK
Optional storage cart for lifting kit

FORE / AFT END LIFT KIT #M140168

SPECIFICATIONS	
Column Configuration	2 columns
Capacity per set	18,000 lbs.
Max. Rise / Floor to top of runway	69" (1760mm)
Fork to column clearance	10" (254 mm)
Adapter reach	12" Narrow Position 43 1/2" Widest Position 9 1/2" Lowest Pickup Height
Speed of rise	78 seconds / 68 seconds



Shown: MCH418U100 with
M140168 frame lift kit
18,000 lbs. capacity lift

Service two
vehicles at once
using a single set
of four columns.



Lift vehicles by the front and rear
the using stacking adapters.

OPTIONAL M140168YL ADAPTER ACCESSORIES

M130242
BALL HITCH ADAPTER

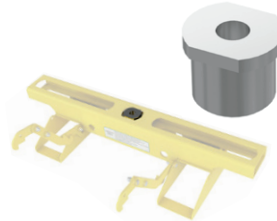

M120651
WIDE CENTER ADAPTER

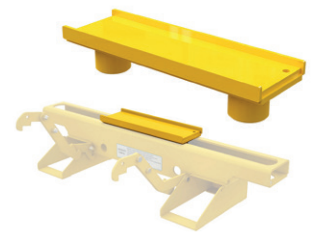

M140180YL
CAB OFF ADAPTER KIT

Contains (4) adapters
on extended arms
and (4) ratchet straps

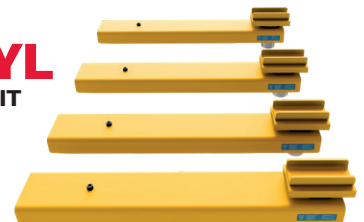

FRAME-ENGAGING CROSS BEAM KITS

Service wheels and tires with ease. Pick up buses, RVs and more with wheels-free, frame-engaging cross beam kits.

For Use with MCHM419 or MCHW418 Series Lifts



Shown: M140070 low profile cross beam with optional jack stands



Shown: FD2448 extra-wide drive-on ramp for wingplow trucks

WARNING:

Never exceed rated capacity.

Refer to operating instructions supplied with lift for proper lifting procedures.

Operate mobile column lifts to desired height.

Always use safety stands as needed or when installing or removing heavy components.



CAUTION:

Never use a bent or damaged crossbeam. Always have an authorized installer make any repairs or replacements. Crossbeams are not to be used as wheel engagement lifts. Do not change or modify the crossbeam in any manner.

M140070YL LOW PROFILE CROSS BEAM KIT

30,000 lbs Capacity
at maximum 49" adapter spread

21,000 lbs. Capacity
at minimum 25" adapter spread

Kit includes single cross beam

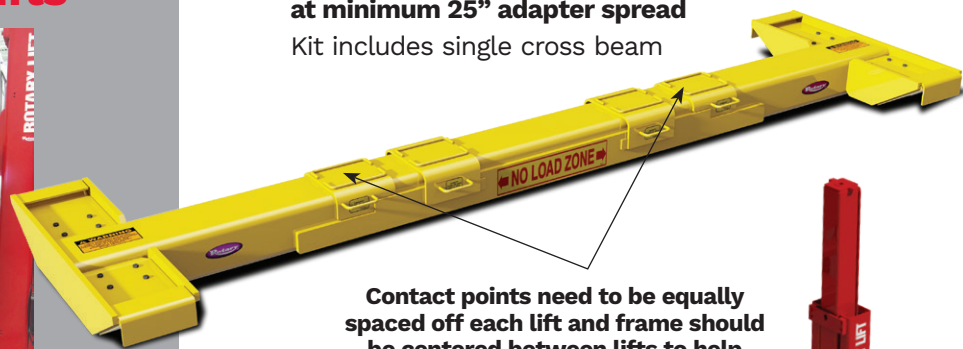

Contact points need to be equally spaced off each lift and frame should be centered between lifts to help prevent offset loading.

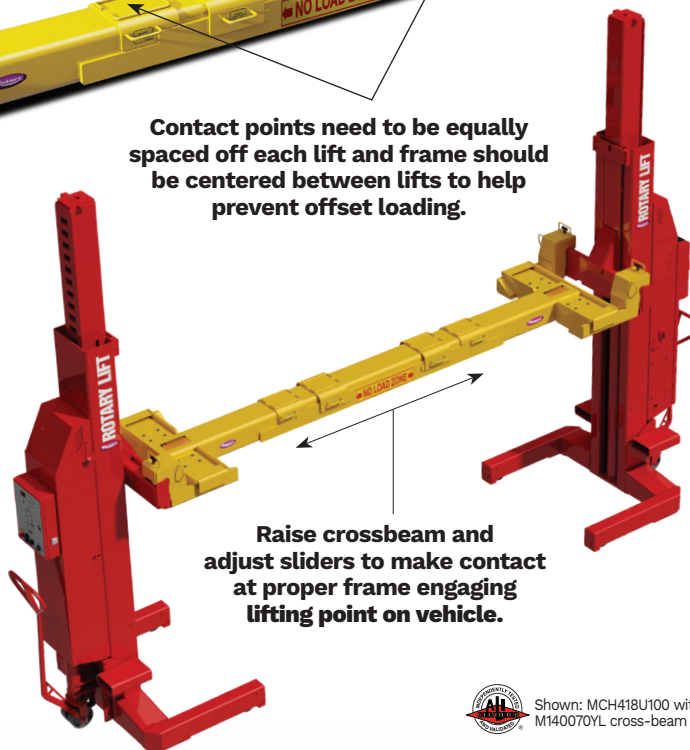

Raise crossbeam and adjust sliders to make contact at proper frame engaging lifting point on vehicle.

Simply push crossbeam lift adapter into desired position under vehicle. Push the mobile column fork arms into beam ends completely until ends of crossbeam rest on the heel of the forks. Raise crossbeam and adjust to contact the frame at proper lifting point.

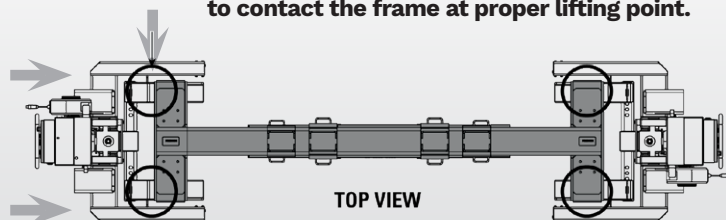

Shown: MCH418U100 with M140070YL cross-beam kit

ML41YL

SADDLE BEAM KIT

32,000 lbs Capacity at maximum
72" adapter spread

24,000 lbs. Capacity at minimum
49" adapter spread

- Kit includes single cross beam
- Two (2) pairs of frame-engaging adapters
- Two each 5" and 8" adapter extensions
- Portable with built in wheel assembly

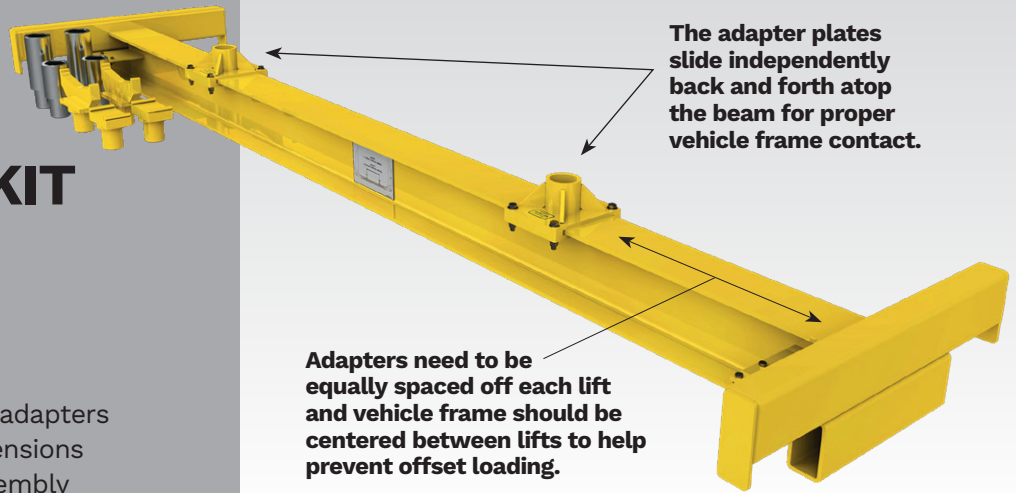

Raise crossbeam and adjust sliding adapters to contact the frame at proper lifting point.

Adapters are for frame engagement only.

DRIVE-ON RAMP STYLE KITS

FD2448KITYL

EXTRA WIDE RAMP FOR WINGPLOW TRUCKS PICKUP

28,000 lbs Capacity
154" Drive-Thru Width

- Kit includes single cross beam

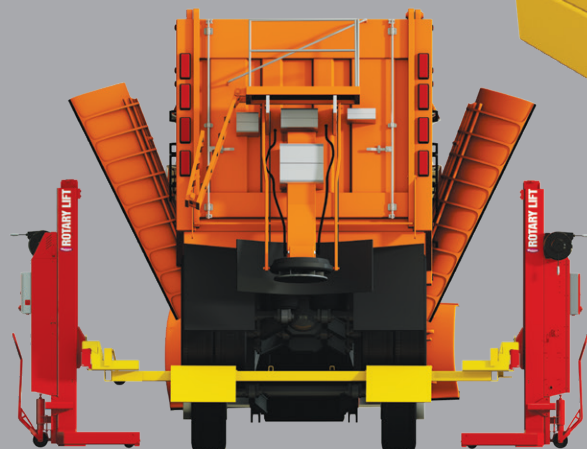

SHOWN: FD2448
EXTRA WIDE DRIVE ON CROSS
BEAM KIT with TOW HANDLE

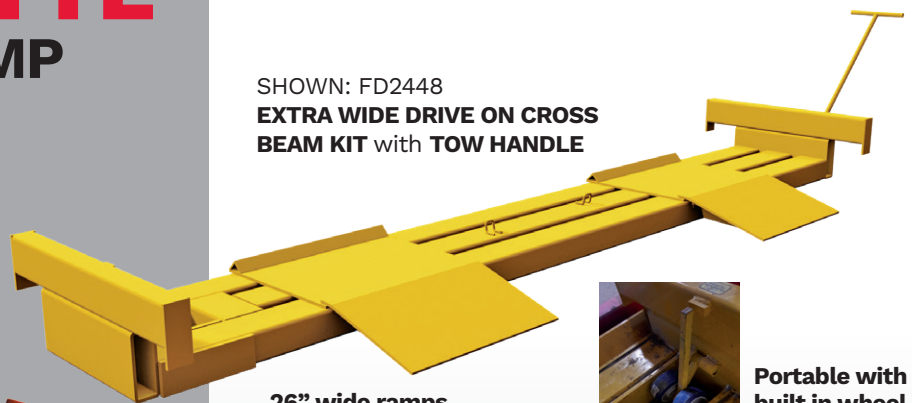

FD2353KITYL

DRIVE-ON BEAM KIT FOR RV PICKUP

22,000 lbs Capacity / 130" Drive-Thru Width

- Kit includes single cross beam
- 26" wide ramps with wheel chocks



CHOOSE THE RIGHT LIFT FOR YOUR SHOP MOBILE COLUMNS



“We wanted a product that was worth the cost and easy to use and supported our core value of safety. What we found with the Rotary lift system is that it helped reduce the number of knee injuries, back injuries and hand injuries.”

- James Enright
Regional Maintenance Director Schneider National

“After extensive testing of multiple mobile column lifts, I chose Rotary mobile lifts as having the most advanced design, most options and ease of relocating being the best choice for the city. After receiving the lifts, Rotary’s customer service and local distributor experience was exceptional.”

- Daniel S. Corbin
Fleet Operations Manager
Summerville, South Carolina

“The thing that really stood out for us was the remote control. We did not see that anyone else would offer that, I think that its definitely helped us be more efficient. Would I recommend Rotary’s FLEX series mobile columns? I absolutely would. The quality is there. The service is there. The parts are available and they’re an American company.”

- Mitch Corwin
Transportation Supervisor
New Albany Floyd County Consolidated School System, New Albany, IN

“Rotary has been a Godsend to us because the main thing is we get vehicles repaired and back on the road quicker. Our down list that we get every day has shrunk to a quarter of the size that is used to be...it makes a huge, huge difference.”

- George Jacobs
President, Windy City Limousine and Bus
Chicago, IL

OPTIONAL LIFT ACCESSORIES Contact the manufacturer for proper lift application

M140112 / Locklight™ Safety Light / MCH Kit
Light indicates when lift is set on its locks. Compatible & retrofitable with DC versions of MCH13 and MCH18 columns.

M140115 / Locklight™ Safety Light / MCH Kit
Light indicates when lift is set on its locks. For MCH columns with pressure gauges already installed.

M140171BK / 24V DC LED Service Lamp Kit
Operates on column’s battery power. Includes 2 lamps. Lights ensure workspace around the lift is well illuminated increasing safety

M140001RD / Long Fork Kit for recessed wheels
Includes two 22" forks and two 8" leg extensions. Reduces capacity of column to 12,000 lbs. For 18K MCH and 19K Flex MAX Models

M140041RD / Long Fork Kit for recessed wheels
Includes two 20" forks and two 8" leg extensions. Reduces capacity of column to 14,500 lbs. For 18K MCHW and 19K FlexMAX Models

M120304BK / Large wheel adapter (per column)
Adapter allows lifting of vehicles with extremely large diameter wheels.

M140157 / Analog Weight Gauge Kit
For MCHW / MCH Series Lifts

M140014 / Service Chip
For standard wired and wireless MCHW lifts

M140024 / Wireless Upgrade Kit 
Add wireless communication to wired column.

Portable Maintenance Jack Stands

RS20SYL / Screw-Type Adjustable
56.1"-82.3" / 20,000 lbs. Capacity

RS2052SYL / Screw-Type Adjustable
34.3 "-55.5" / 20,000 lbs. Capacity

RS20-VAYL / V-Shaped Adapter
For 20K Jack Stands - 1 per stand



All jack stands meet the required ASME PASE-2014 safety requirements for portable service equipment.

Always use safety stands when installing or removing heavy components.

Air Operated Tire and Wheel Lifts

- Adjustable lifting and lowering speeds
- Responsive positioning of the tire and wheel
- Easy alignment of wheel and hub
- Quick transfer to the wheel balancer
- Includes air hose and auxiliary air tool connection

MW-200 / 200 lbs. capacity
MW-500 / 500 lbs. capacity

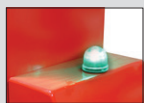

M140112



M140171BK



M140001RD



M120304BK



M140157



Rotary is the world leader in service bay solutions offering a broad range of equipment and accessories to make any service bay safer and more productive.

For a complete guide to our product offering or to contact your local distributor, visit us at www.rotarylif.com today.

If you need assistance or have questions, we're here to help

800.445.5438 / Sales: insidesales@vsgdover.com / Support: technicalsupport@rotarylif.com



ROTARY

2700 Lanier Drive
Madison, IN 47250, U.S.A.



Lit# Rotary Mobile Column Series Brochure.2023.04

©2023 VEHICLE SERVICE GROUP™
All Rights Reserved. Unless otherwise indicated, ROTARY, VEHICLE SERVICE GROUP™, DOVER and all other trademarks are property of Dover Corporation and its affiliates. Printed in U.S.A.

Product specifications, part numbers, images and component descriptions are subject to change without notice or liability.